



 FORGEON

MITHRIL

INSTRUCTIONS MANUAL
MANUAL DE INSTRUCCIONES

TECHNICAL SPECIFICATIONS

MODEL	MITHRIL
DIMENSIONS (L x W x H)	460mm x 231mm x 490mm
WEIGHT	7,95Kg
MATERIAL	Steel 0,7mm SPCC, Tempered glass
FANS LOCATION	Front: 3x 120mm (3x A-RGB included) 3x 140mm
	Rear: 1x 120mm (1x A-RGB included) 1x 140mm
	Top: 3x 120mm 2x 140mm
	PSU Bay : 1x 120mm
WATER COOLING	Front: Radiador hasta 360mm
	Top: Radiador hasta 360mm
	Rear: Radiador hasta 120mm
DRIVE BAYS	3x 2,5" + 2x 3,5"/2,5"
EXPANSION SLOTS	x7
	2x USB 3.0
	1x USB 2.0
	1x USB-C
FRONT I/O	Auricular/Microfono x1
	Encendido/Apagado
	LED
	Reinicio
DUST FILTER	1x Superior
	1x Frontal
	1x Inferior
MOTHERBOARD TYPE	E-ATX, ATX, MicroATX, ITX
POWER SUPPLY	ATX up to 190mm (not included) bottom position
VGA (GPU)	Up to 380mm (not included)
CPU COOLER	Up to 175mm (not included)

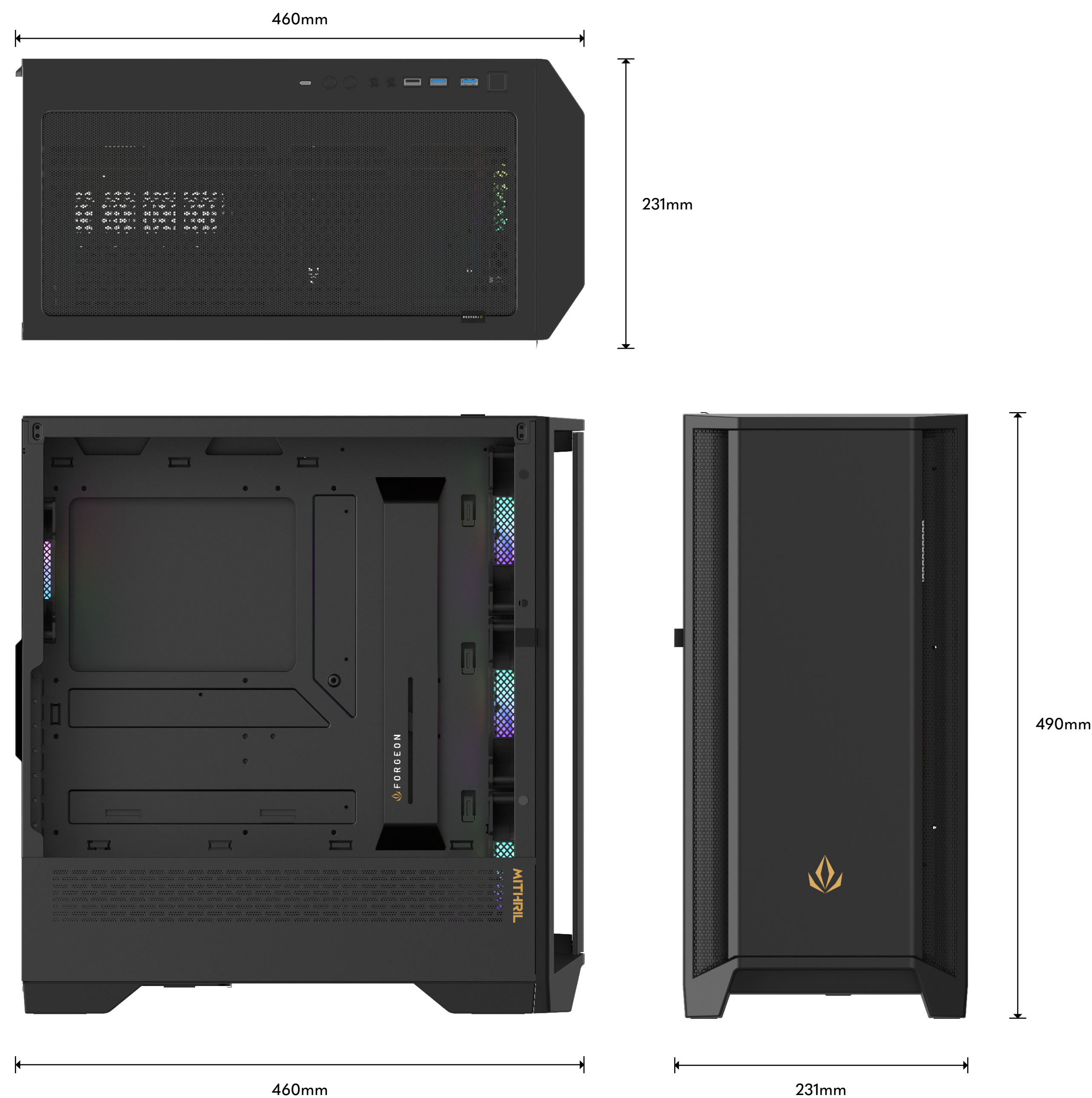

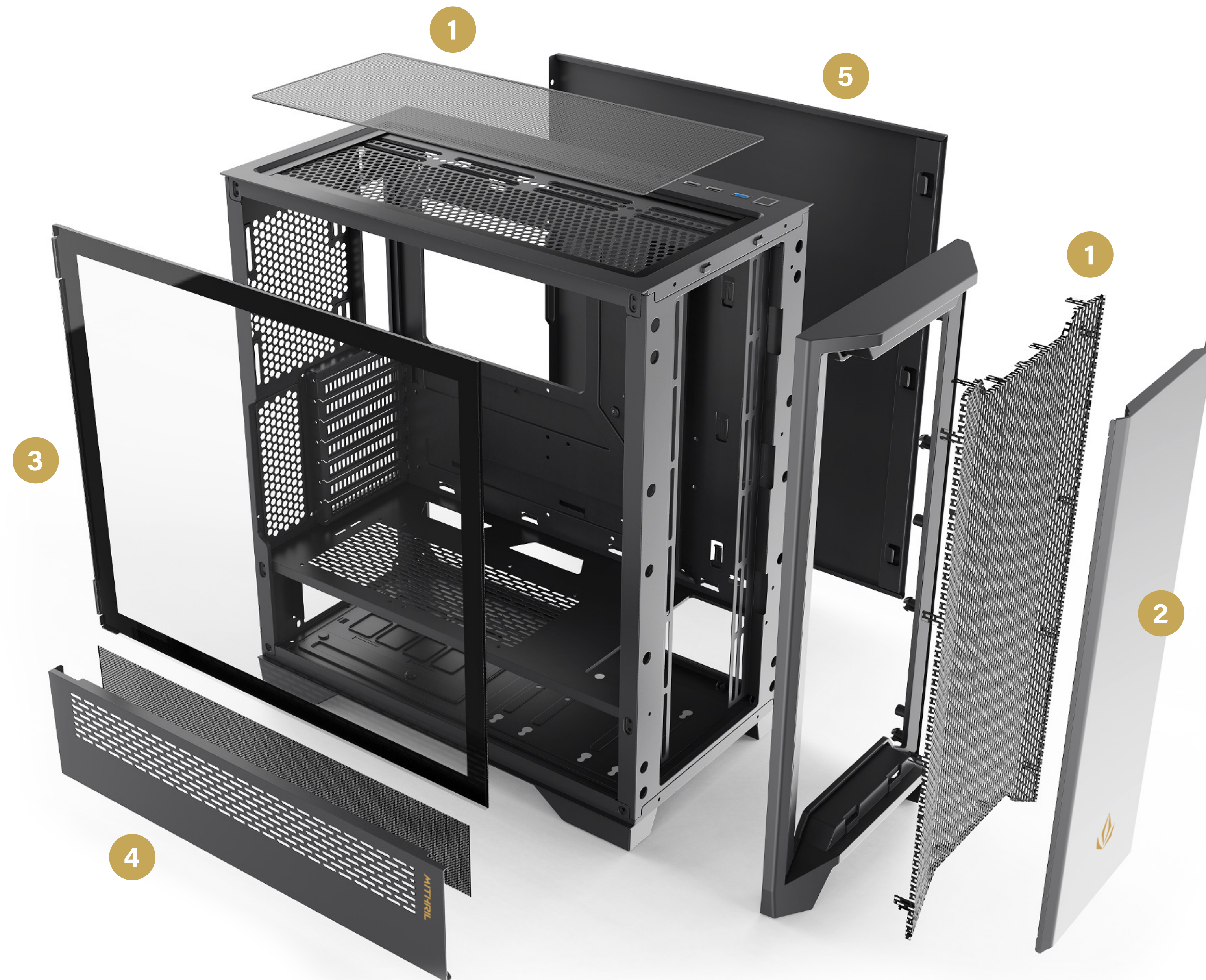

MITHRIL DIAGRAM

- 1 Dust filters
- 2 Detachable front
- 3 Tempered glass
- 4 Power supply panel
- 5 Rear panel

FRONT PANEL I/O AND MOTHERBOARD CONNECTORS

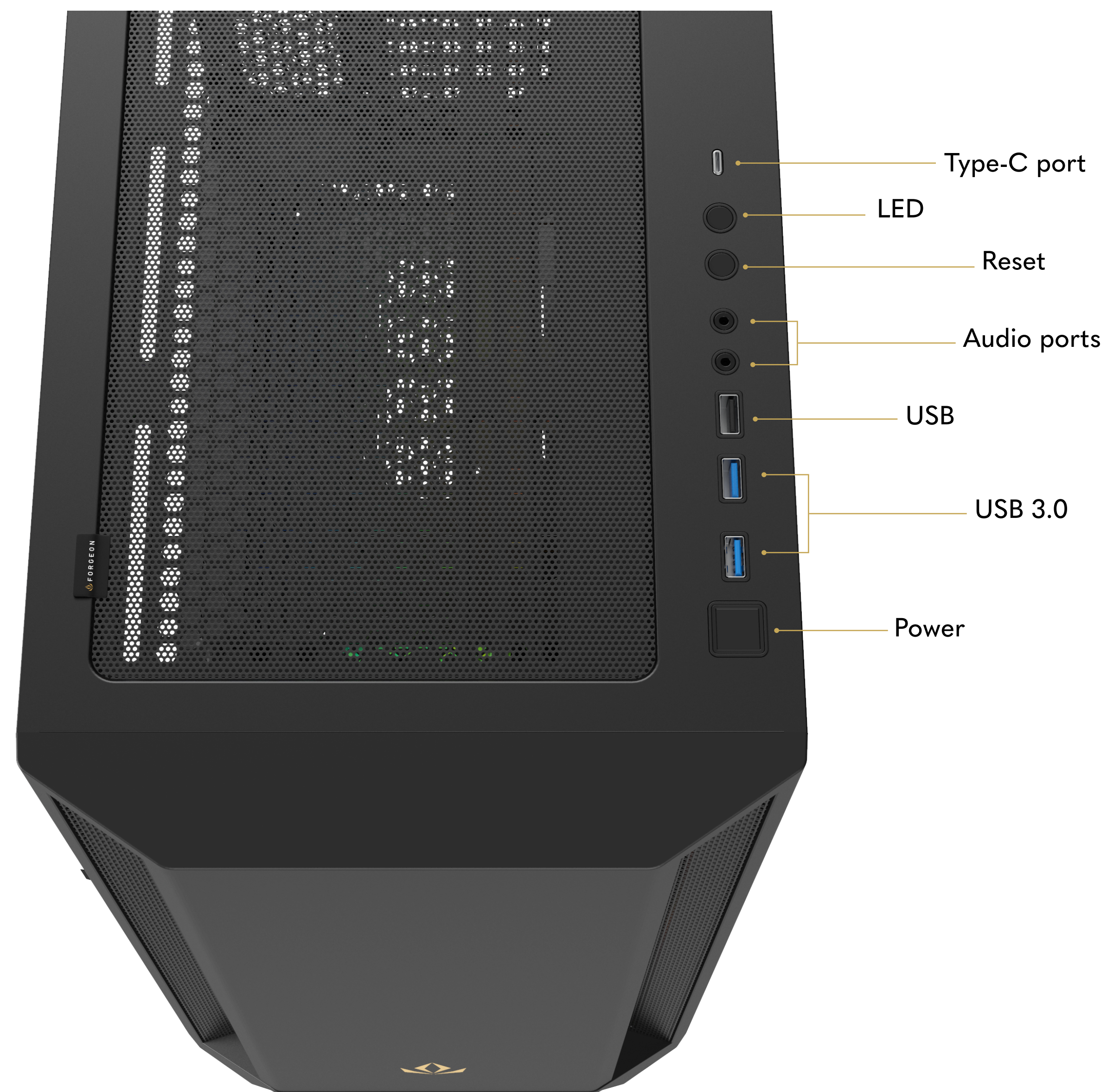

ACCESSORY BAG

EN

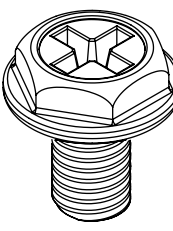
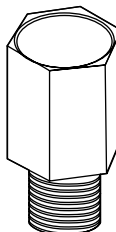
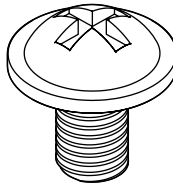
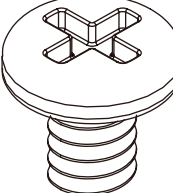
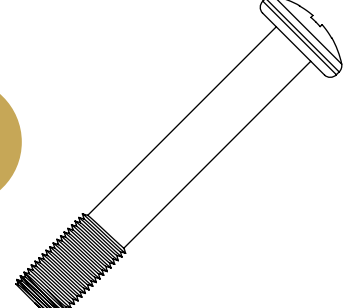
-  **x6** PSU screws
-  **x6** Motherboard standoffs
-  **x24** Motherboard/SSD Screws
-  **x8** HDD bay Screws
-  **x8** Extended fan screws

BASIC INSTALLATION

A Disassemble the side panel and the front panel.

B Install the power supply.

C Install the motherboard.

D Install HDD/SSD.

E Install VGA card

F Install fan and radiator (optional).

G Fanhub controller installation

A

Disassemble the side panel and the front panel.



Special attention to the tempered glass side panel.
Handle with care.

EN

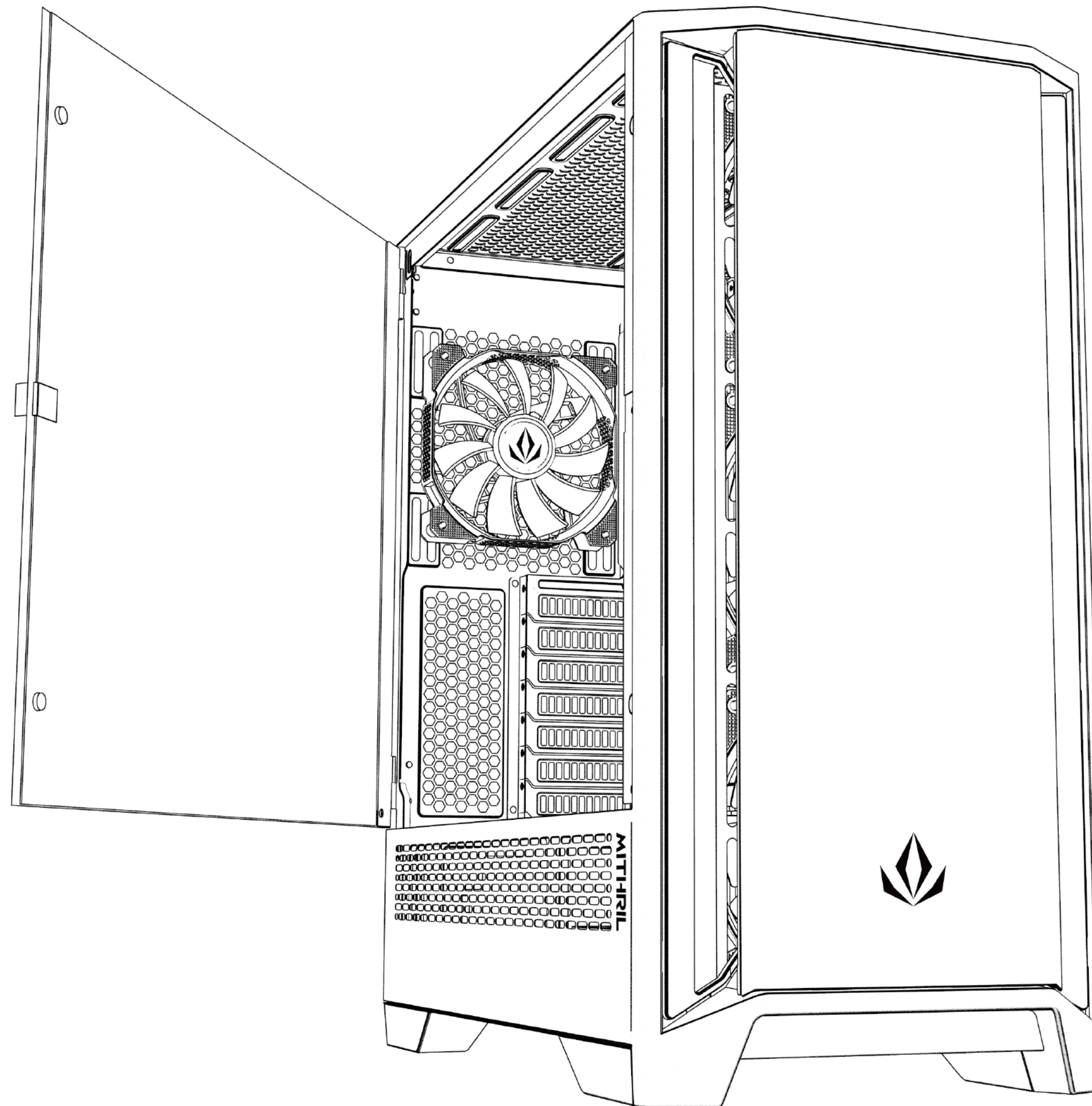

Unfold the tempered glass to the 180° position and remove it from the hinges.

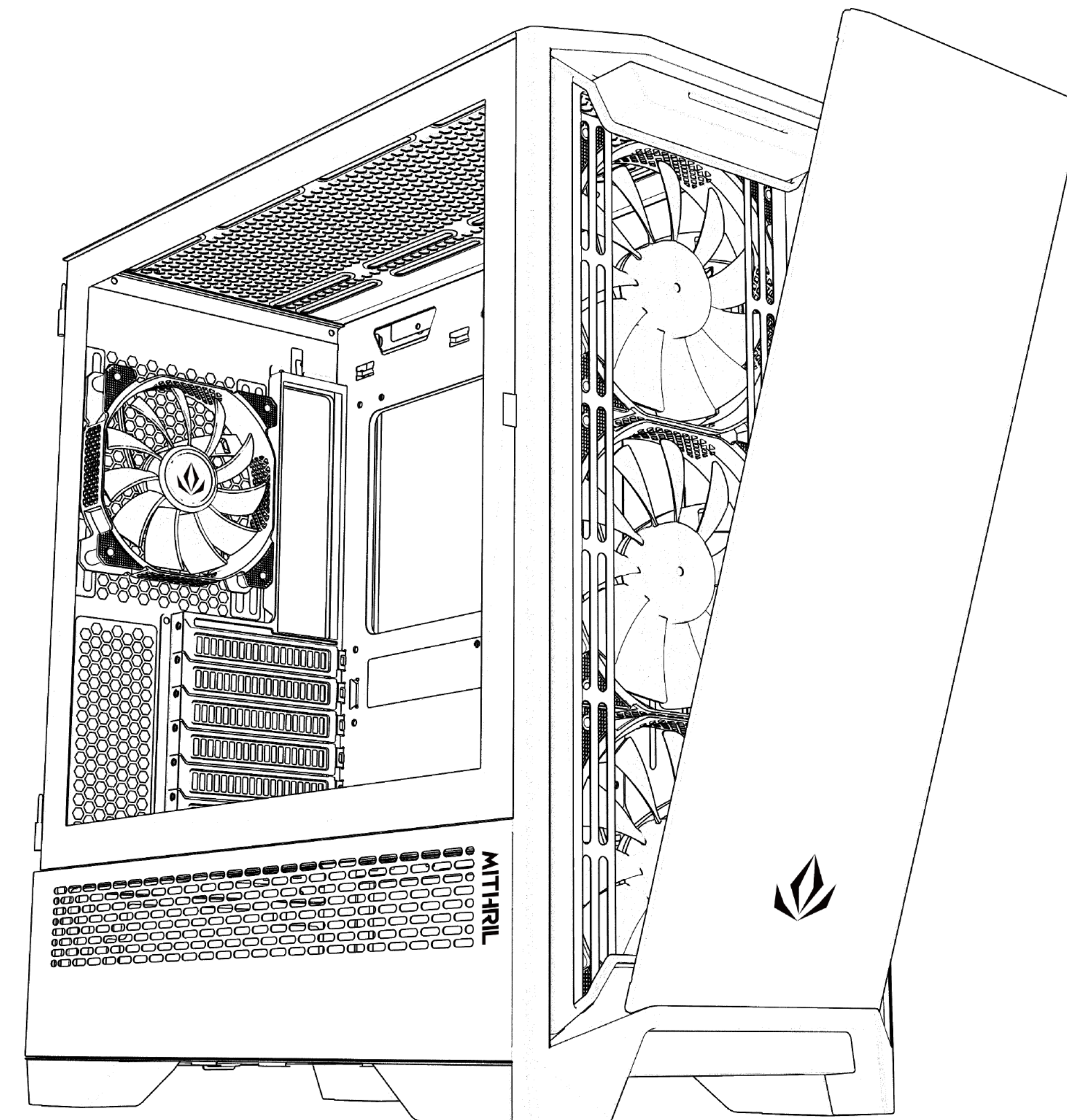

Remove the side panels before disassembling the front panel.

B Install the power supply.

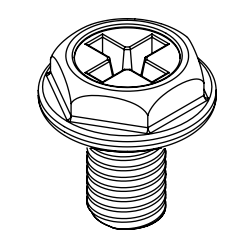
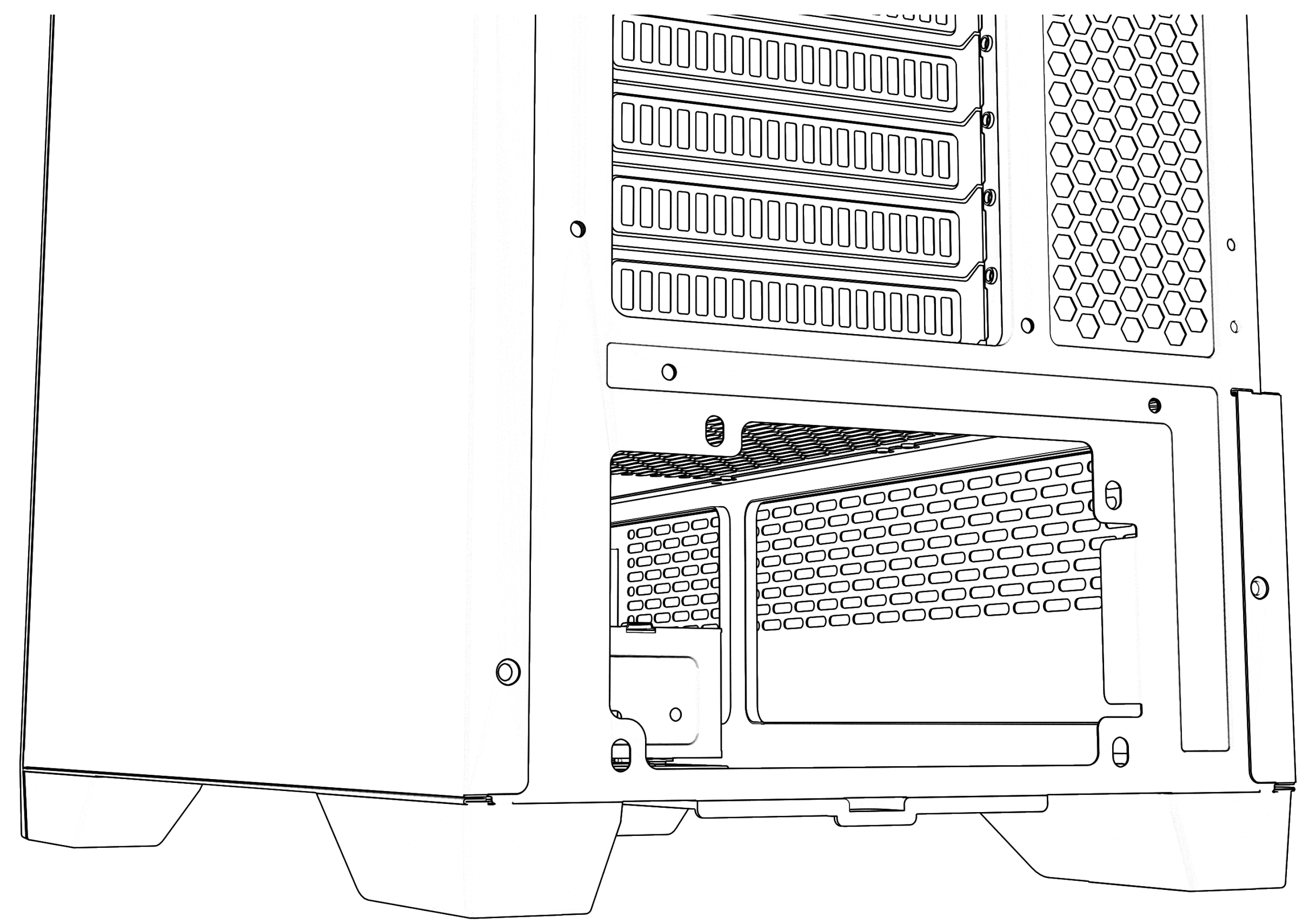

Make sure the screw holes for PSU and the PC case are aligned before screwing.

C Install the motherboard.

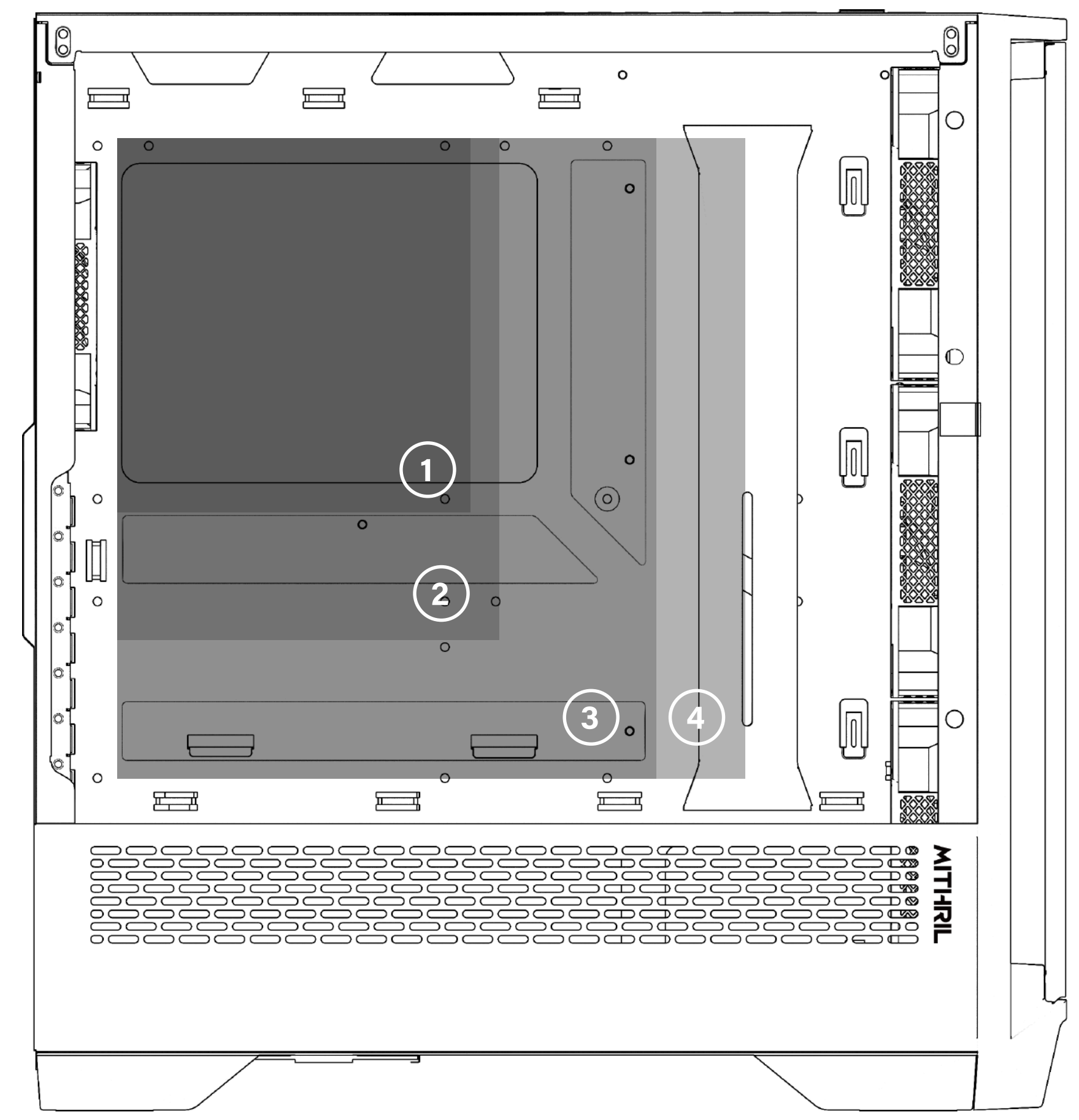

Make sure that the motherboard aims at the copper cylinder and install the standoffs (No.2) before screwing in with the No.3 screws.

D

Install HDD/SSD.

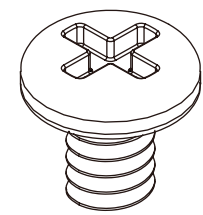
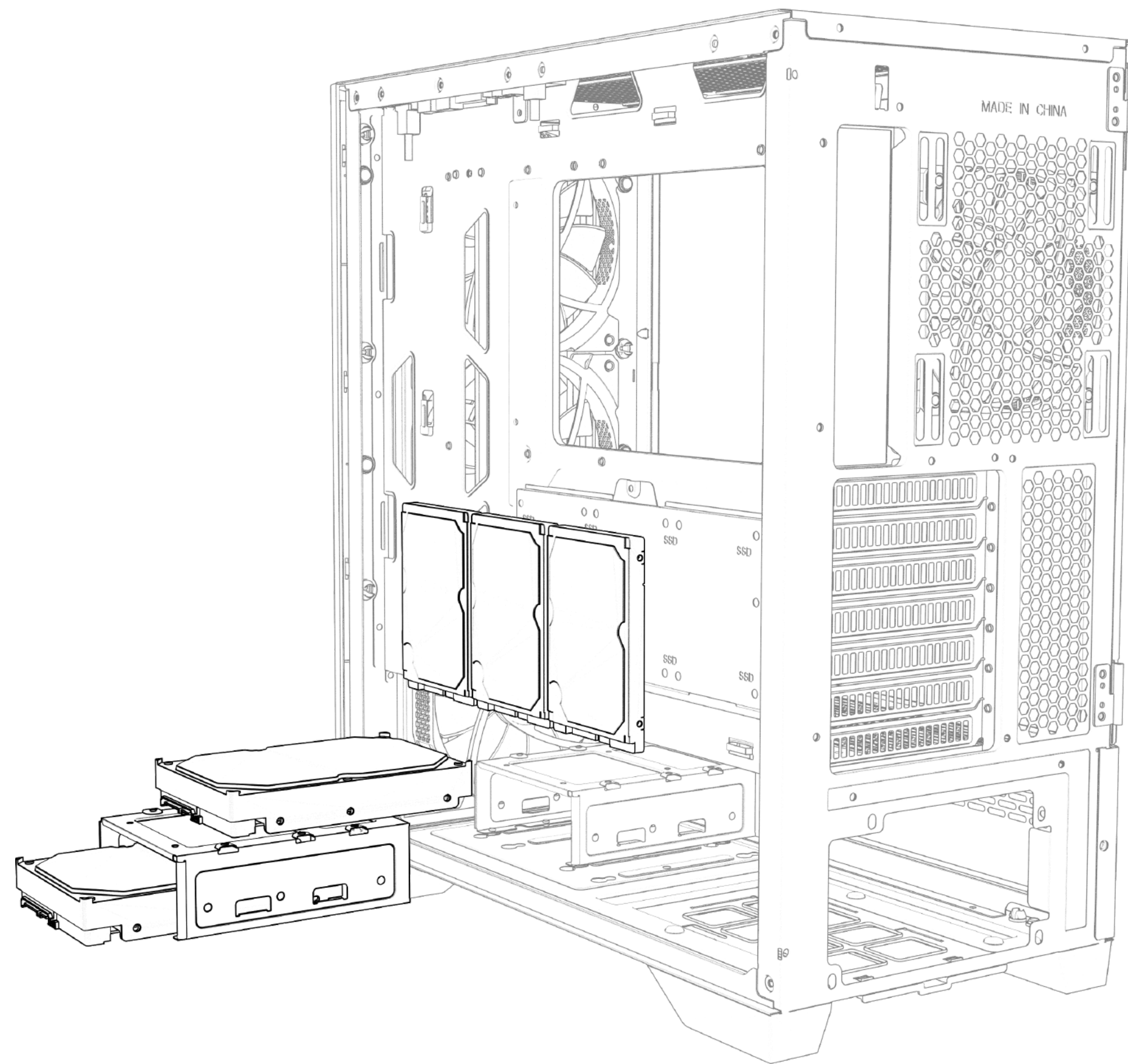

Take off the hard disk enclosure for both HDD and SSD and install it with No.3/4 screws

E

Install VGA card

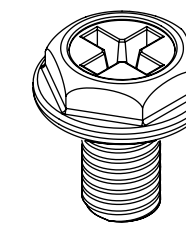
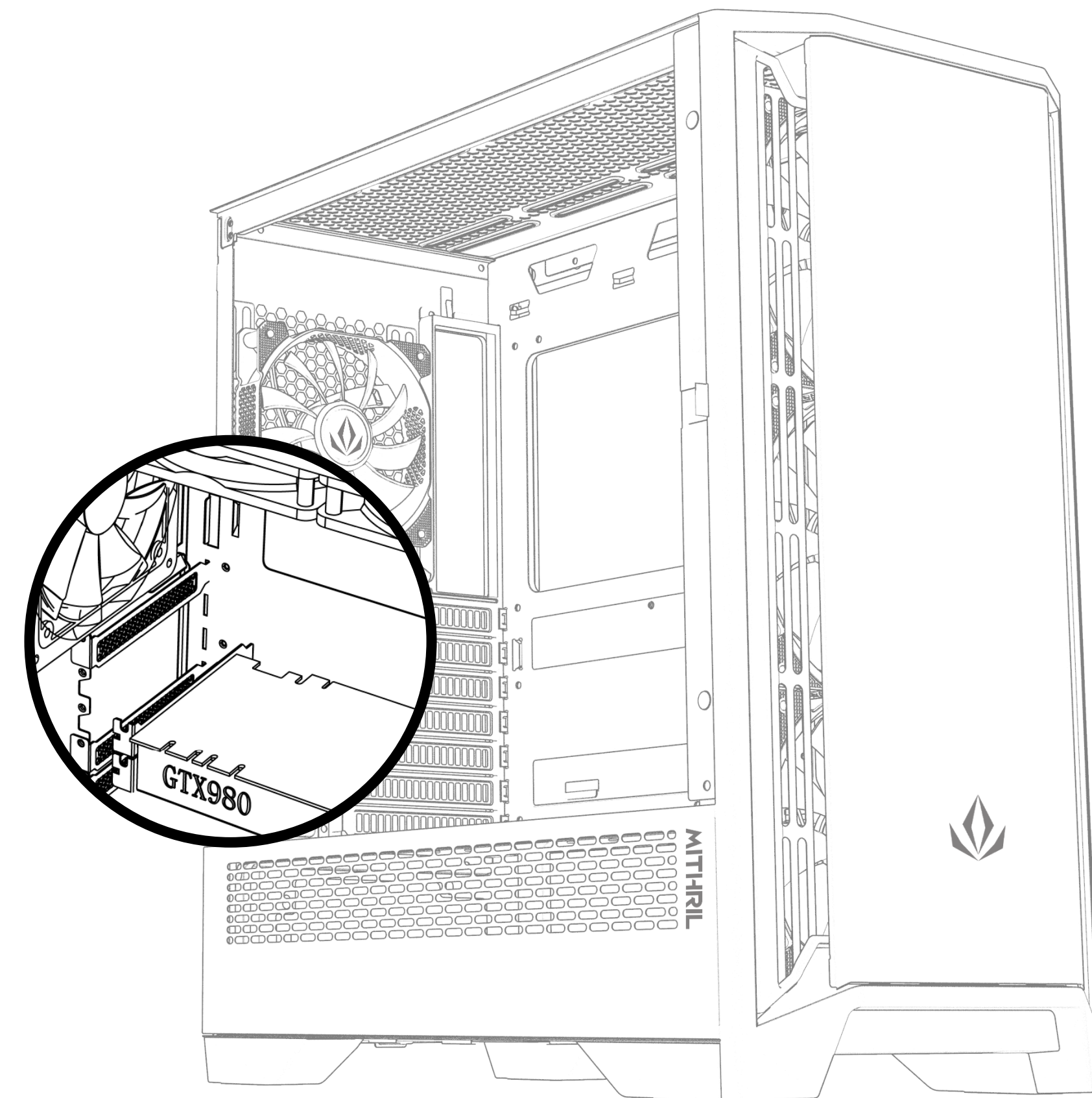

Remove the baffle marked in the picture, make sure the VGA card aims at the motherboard slot and then fix VGA card and case with No.1 screw.



Install fan and radiator (optional).

(A)

FRONTAL

Fans	→ 3x 120mm → 3x 140mm
Radiator	up to 360mm

(B)

TOP

Fans	→ 3x 120mm → 3x 140mm
Radiator	up to 360mm

(C)

REAR

Fans	→ 1x 120mm → 1x 140mm
Radiator	up to 120mm

(D)

BOTTOM

Fans	→ 1x 120mm
------	------------

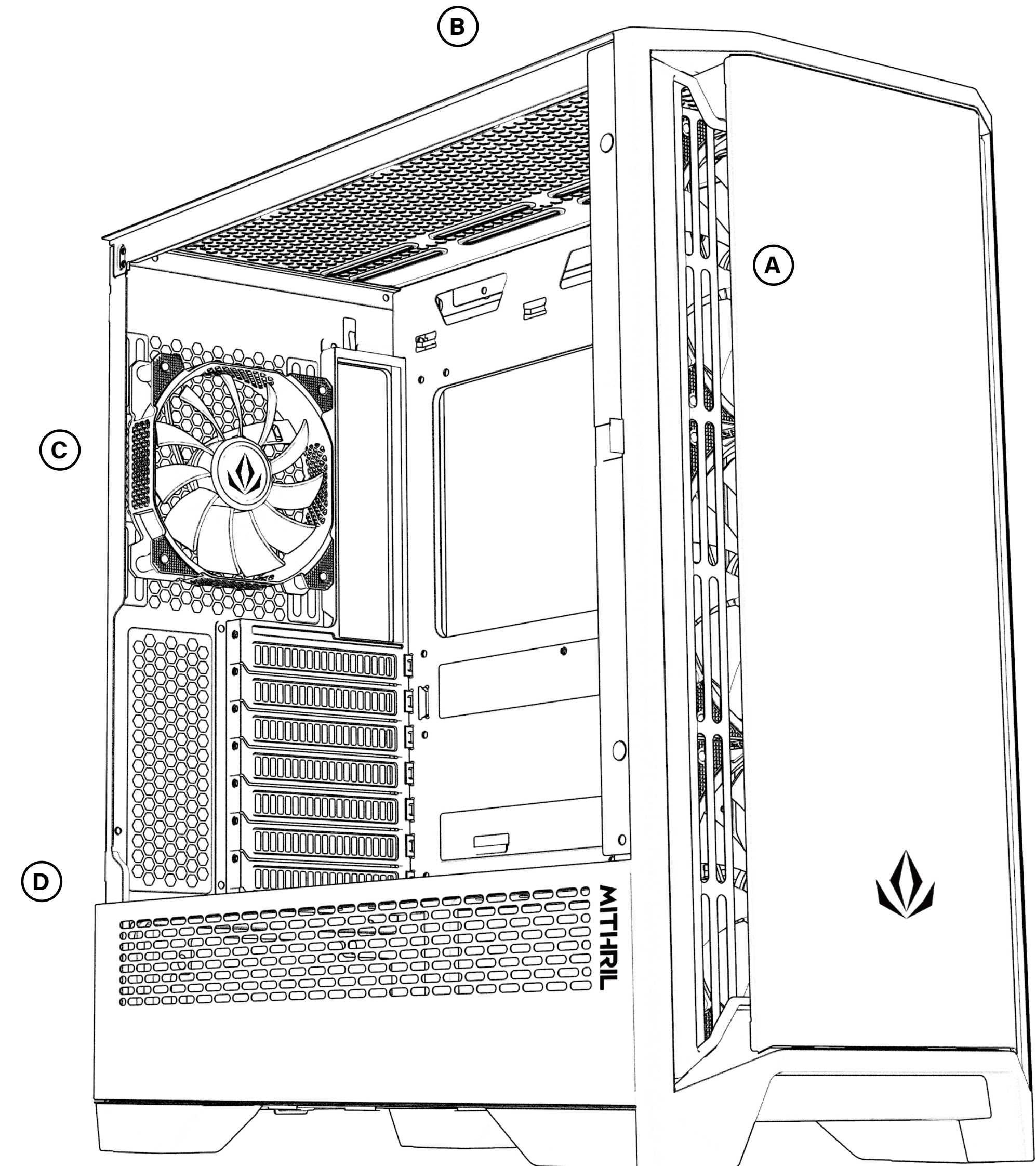

G

Fanhub controller installation

- A** 5v 3pin A-RGB Connector
- B** 3pin power connector
- C** 4pin (PWM) connector and 5v 3pin A-RGB syncing for motherboard
- D** SATA connector to PSU power



Controller has 4pin power outputs(PWM),If the fan has 3pin connect it skipping the last starting from left side

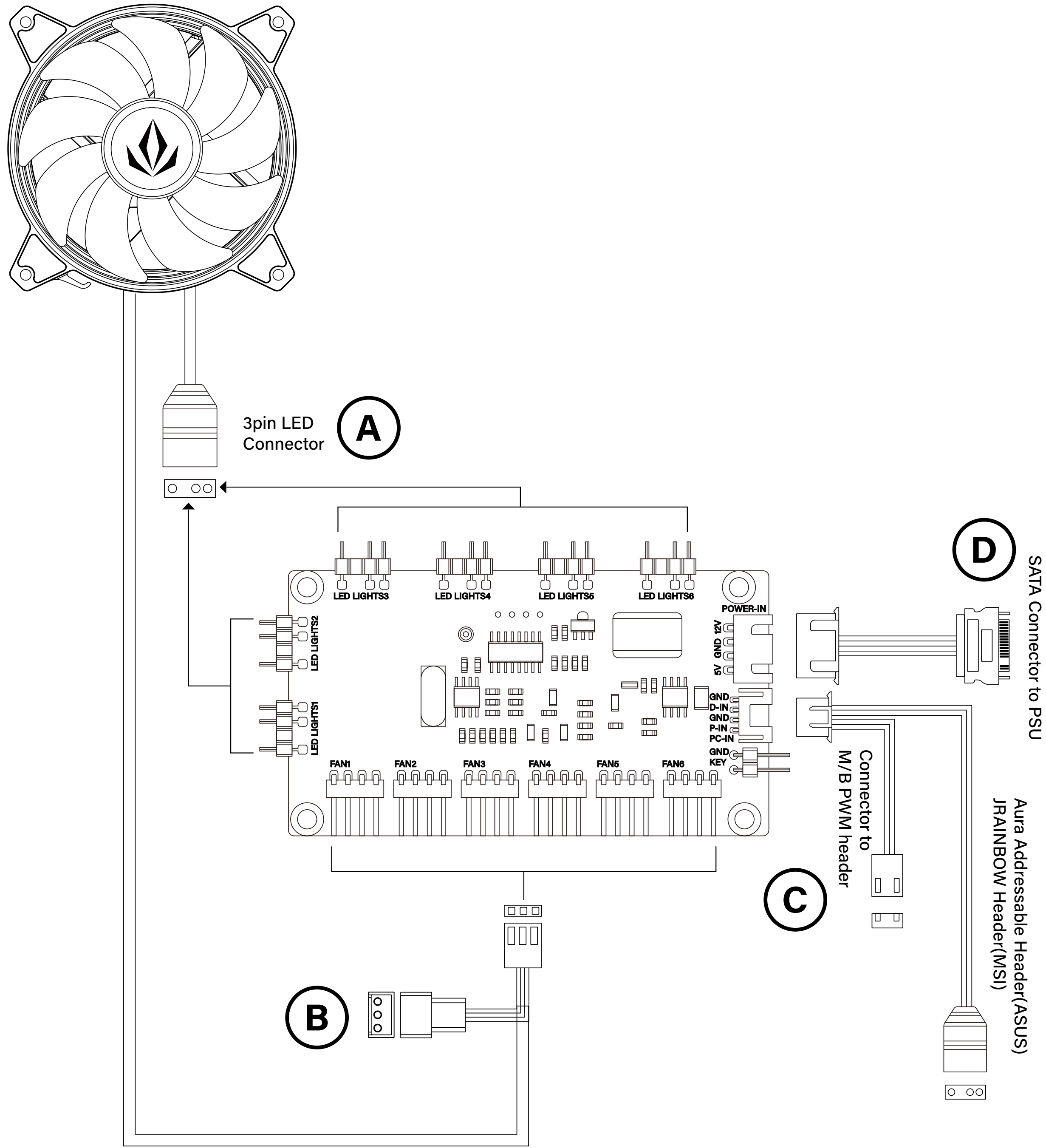

ESPECIFICACIONES TÉCNICAS

ES

MODELO	MITHRIL
DIMENSIONES (L x An x Al)	460mm x 231mm x 490mm
PESO	7,95Kg
MATERIAL	Acero 0,7mm SPCC, cristal templado
UBICACIÓN DE VENTILADORES	Delantero: 3x 120mm (3x A-RGB incluidos) 3x 140mm
	Trasero: 1x 120mm (1x A-RGB incluido) 1x 140mm
	Superior: 3x 120mm 2x 140mm
	Base : 1x 120mm
REFRIGERACION LIQUIDA	Delantero: Radiador hasta 360mm
	Superior: Radiador hasta 360mm
	Trasero: Radiador hasta 120mm
BAHÍAS PARA DISCOS	3x 2,5" + 2x 3,5"/2,5"
RANURAS DE EXPANSION	x7
	2x USB 3.0 1x USB 2.0 1x USB-C
E/S FRONTAL	Auricular/Microfono x1
	Encendido/Apagado
	LED
	Reinicio
FILTROS ANTIPOLVO	1x Superior
	1x Frontal
	1x Inferior
TIPO DE PLACA BASE	E-ATX, ATX, MicroATX, ITX
FUENTE DE ALIMENTACION	Formato ATX hasta 190mm (no incluida) colocada en la parte inferior
TARJETA GRÁFICA (GPU)	Hasta 380mm (no incluida)
DISIPADOR CPU	Hasta 175mm (no incluido)

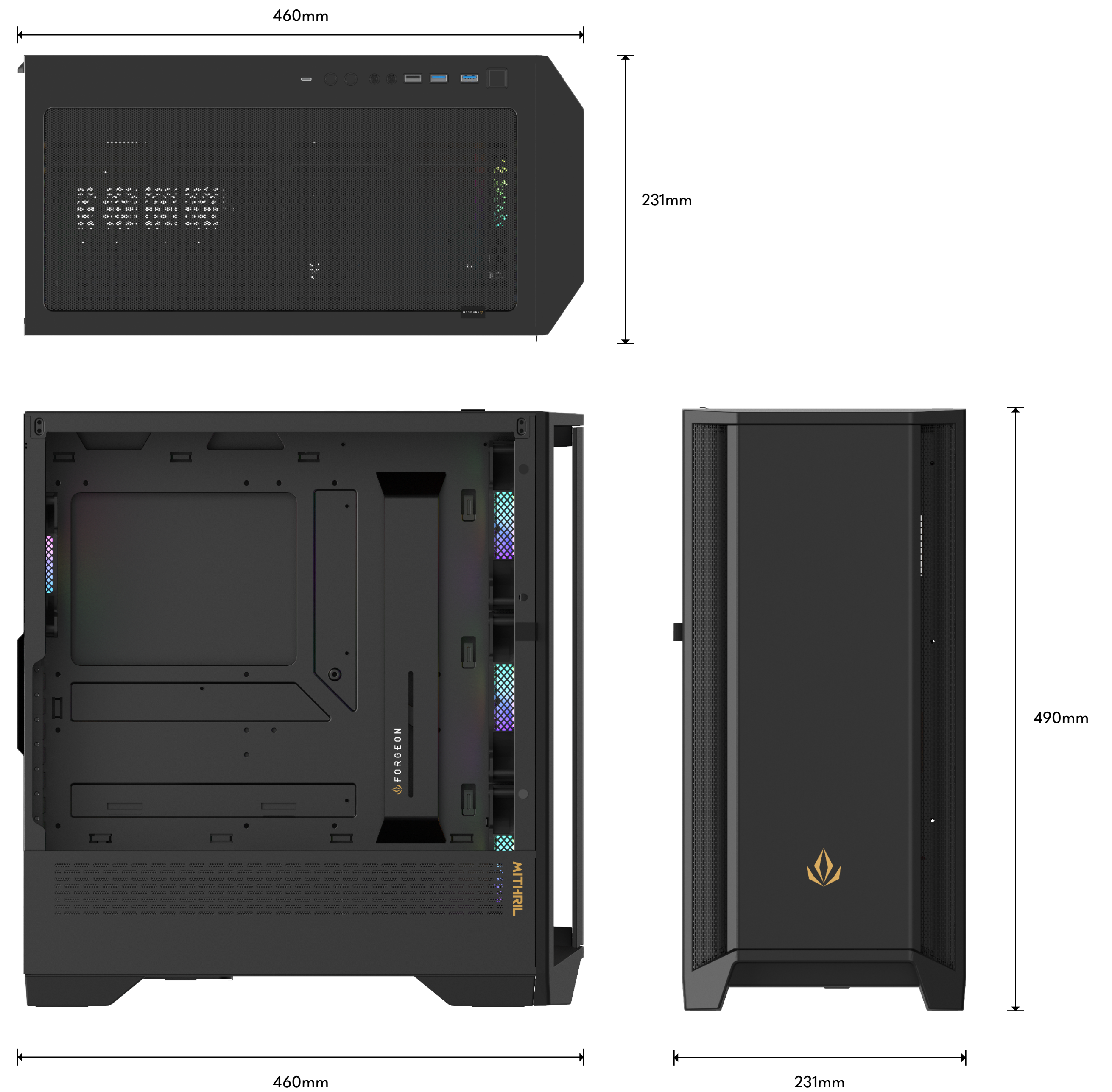



DIAGRAMA DE MITHRIL

- 1 Filtros antipolvo
- 2 Frontal desmontable
- 3 Cristal templado
- 4 Panel de fuente de alimentación
- 5 Panel trasero

PANEL FRONTAL DE E/S Y CONECTORES PARA PLACA BASE

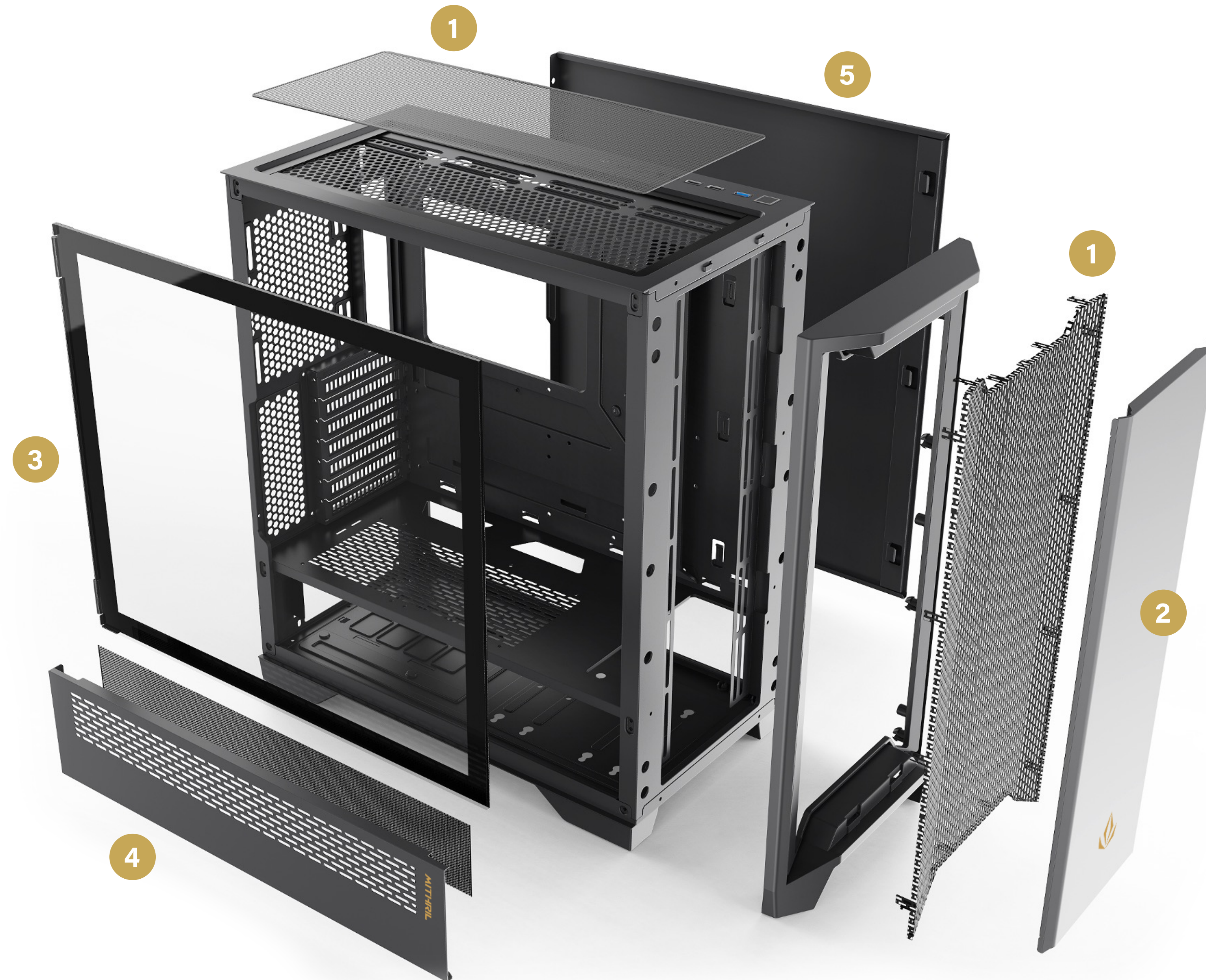
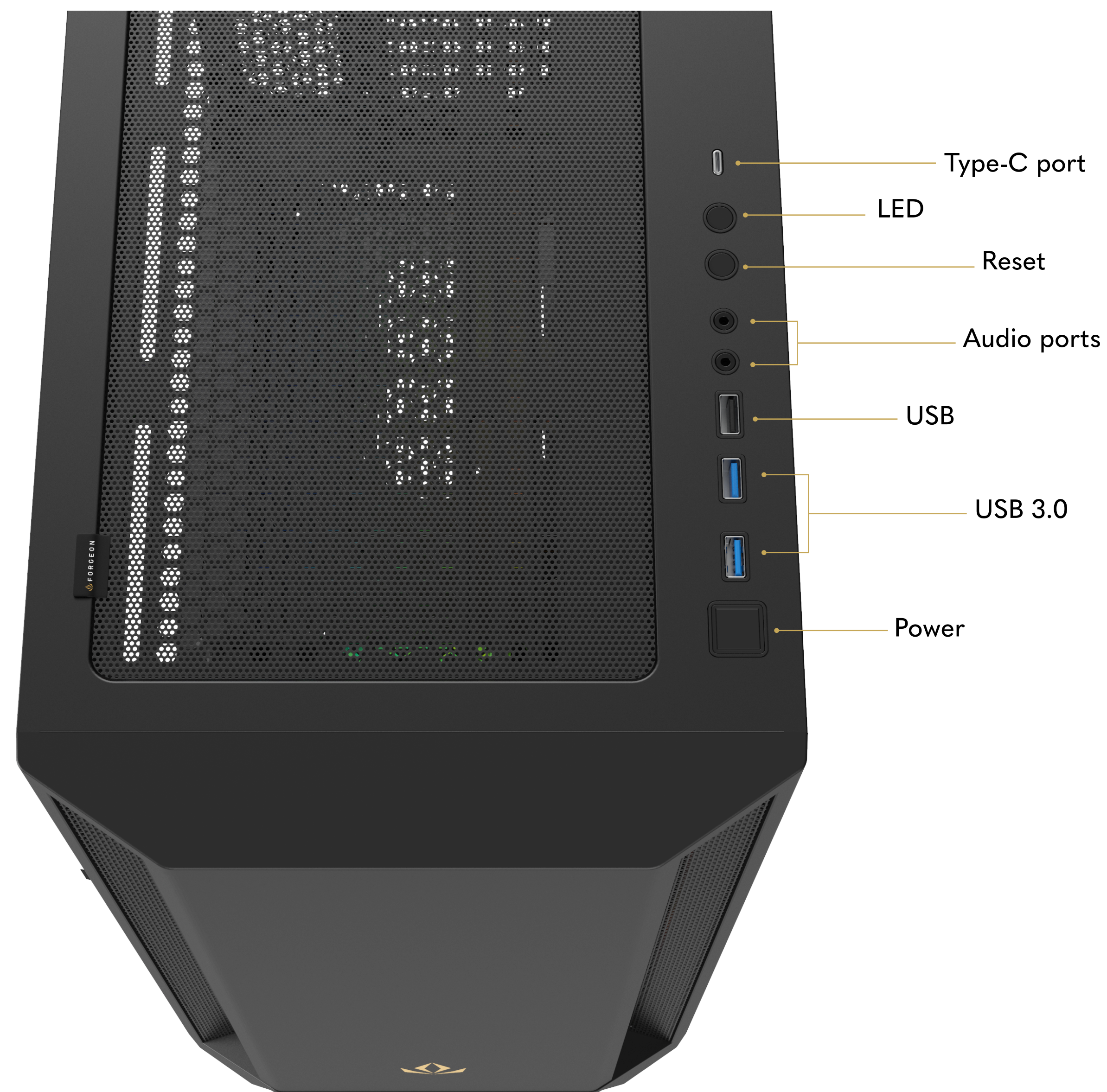

ACCESORIOS PARA INSTALACION

ES

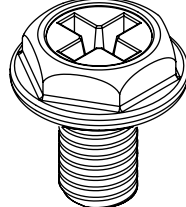
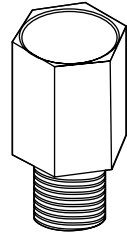
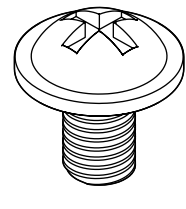
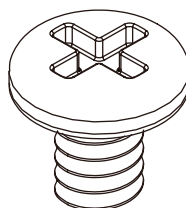
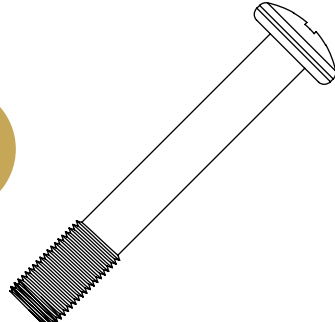
-  **x6** Tornillos para Fuente de alimentación
-  **x6** Soportes para placa base
-  **x24** Tornillos para Placa base/SSD
-  **x8** Tornillos para Bahía disco duro
-  **x8** Tornillos de ventiladores extendidos

INSTALACIÓN BÁSICA

- A** Desmontar los paneles laterales y el panel frontal.

- B** Instalación de la fuente de alimentación

- C** Instalación de la placa base.

- D** Instalación de discos duros HDD/SSD.

- E** Instalación de tarjeta gráfica y desmontar el slot de expansión PCI.

- F** Instalación de ventiladores y/o radiadores (opcional).

- G** Configuración e instalación de la controladora RGB

A

Desmontar los paneles laterales y el panel frontal.



Precaución al desmontar el panel de cristal templado.
Manejar con cuidado.

ES

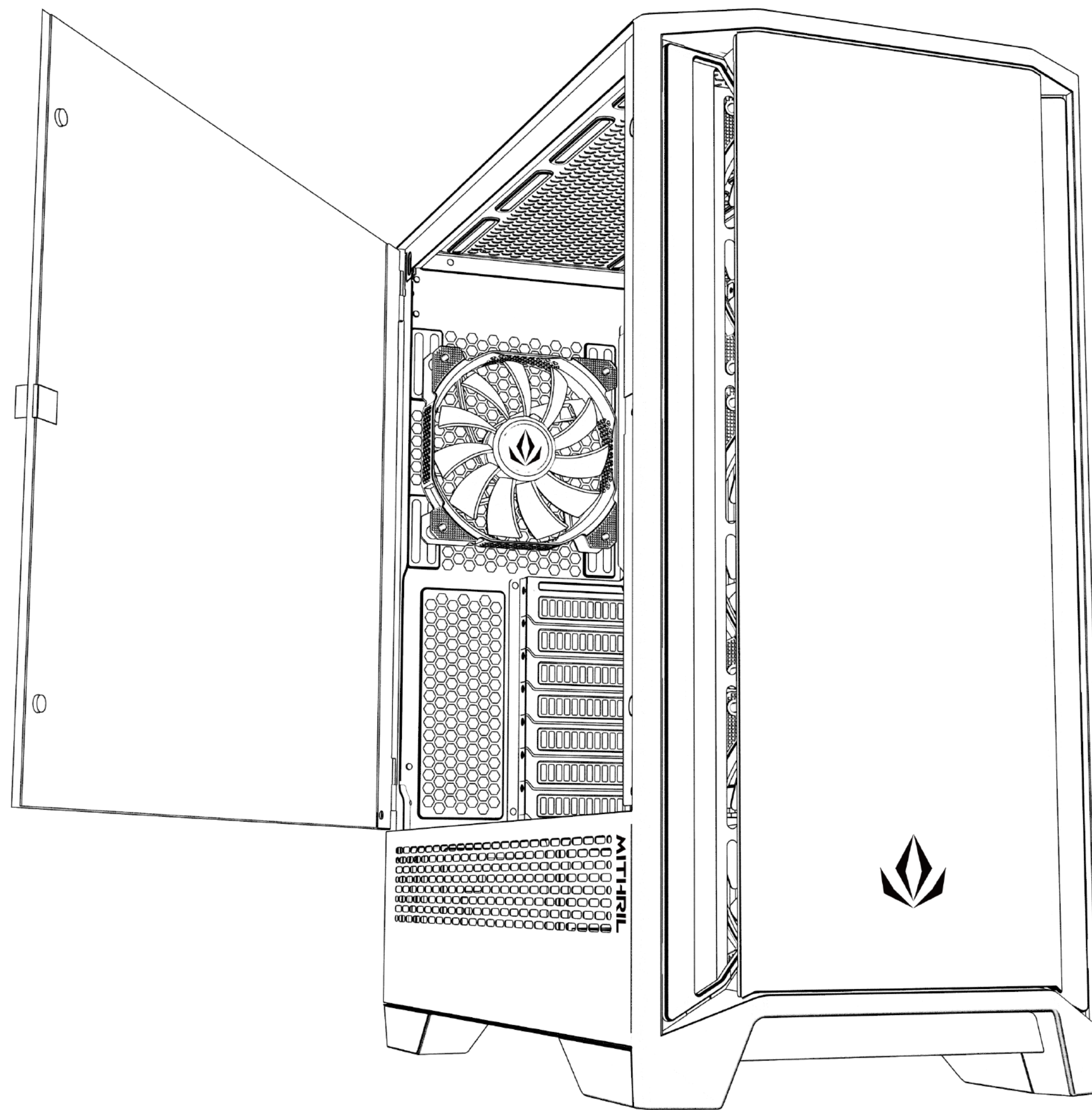

Despliega el cristal templado hasta la posición de 180° y sácalo de las bisagras

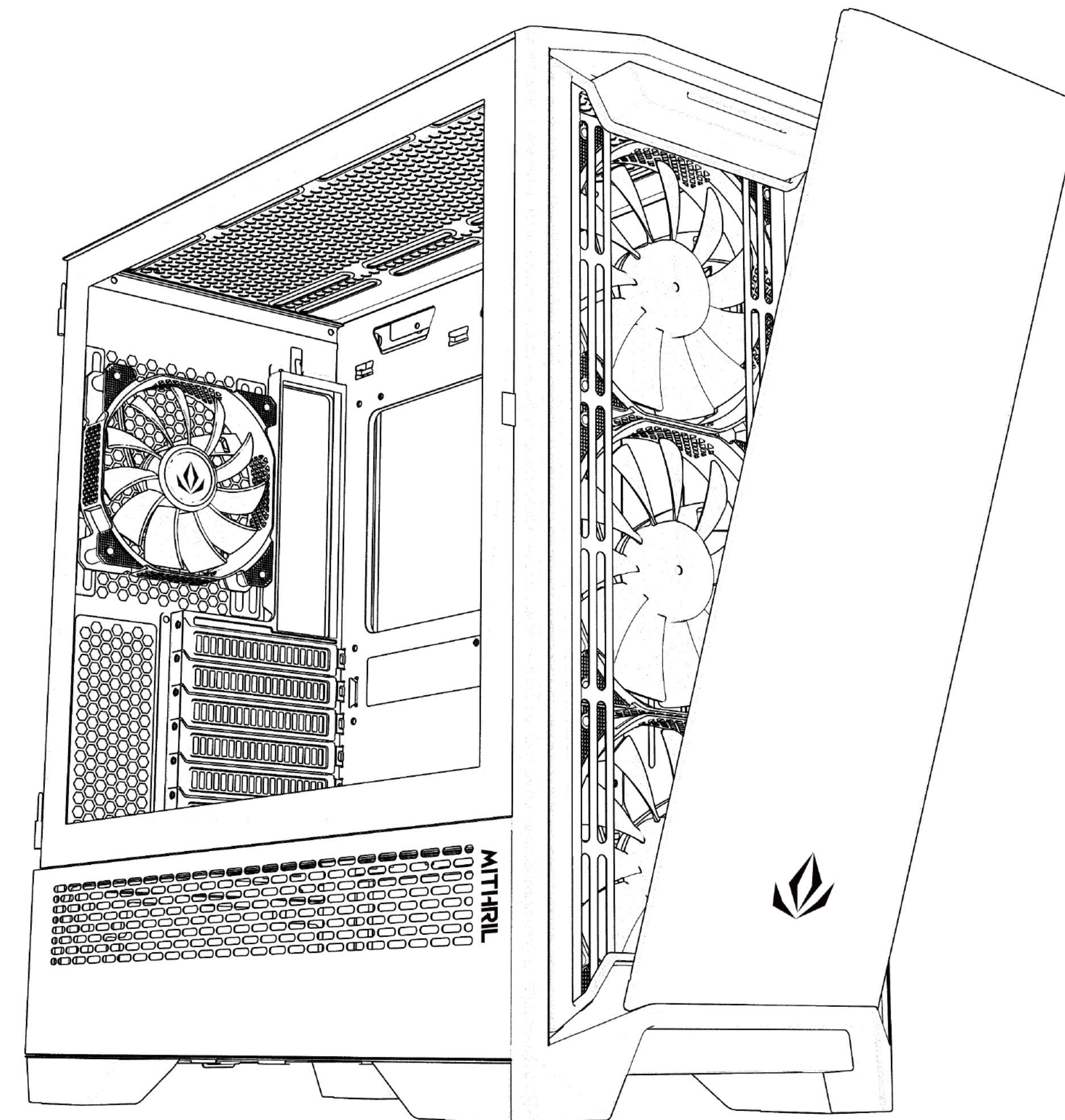

Quitar previamente los paneles laterales antes de poder desmontar el Panel frontal.

B

Instalación de la fuente de alimentación

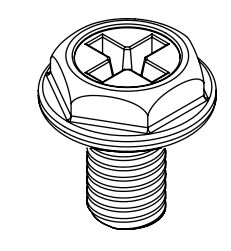
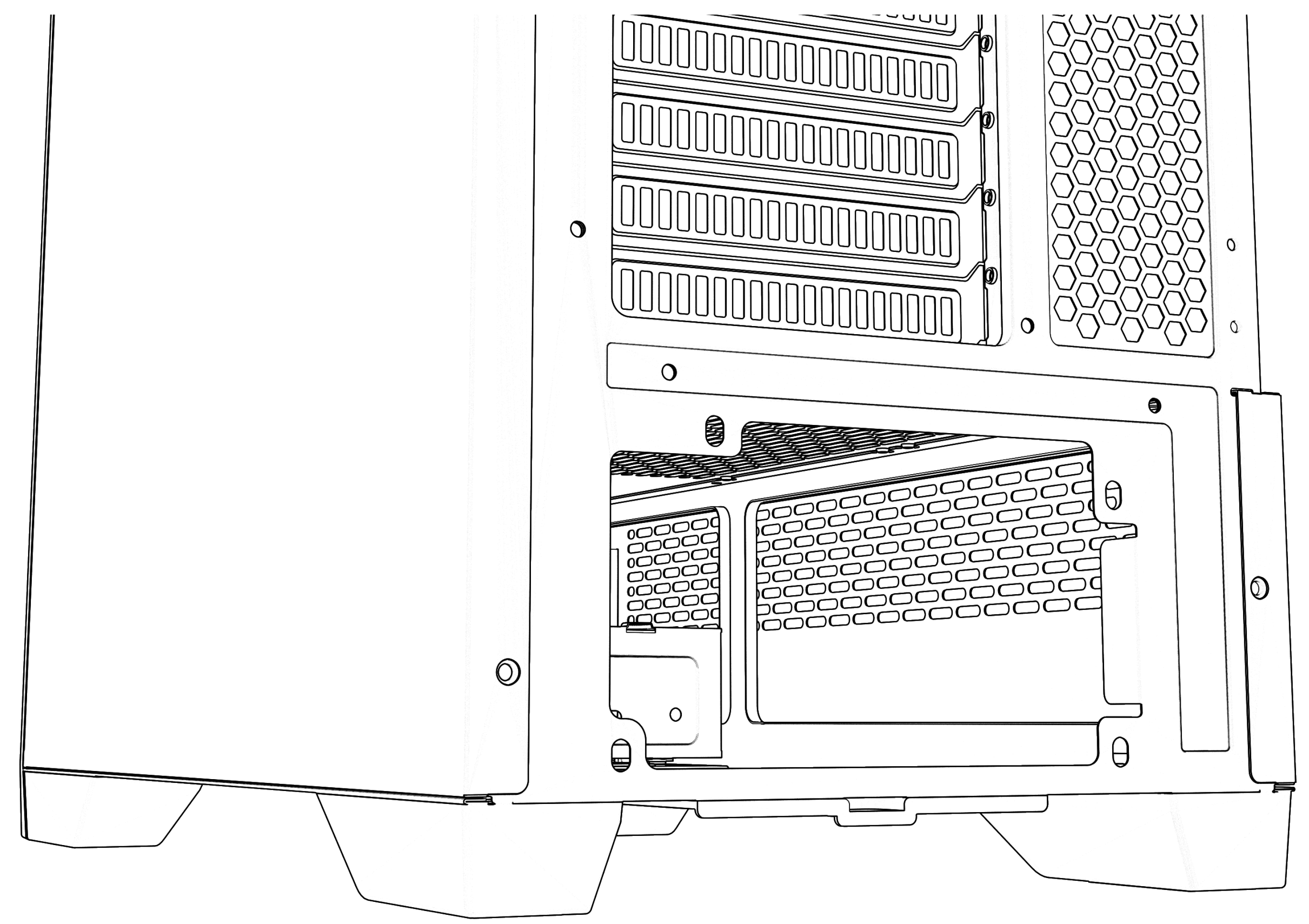

Asegúrate que los huecos para los tornillos de la fuente de alimentación se alinean de manera correcta con los de la torre antes de atornillar.

C

Instalación de la placa base.

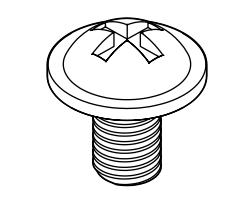
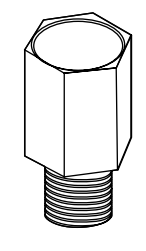
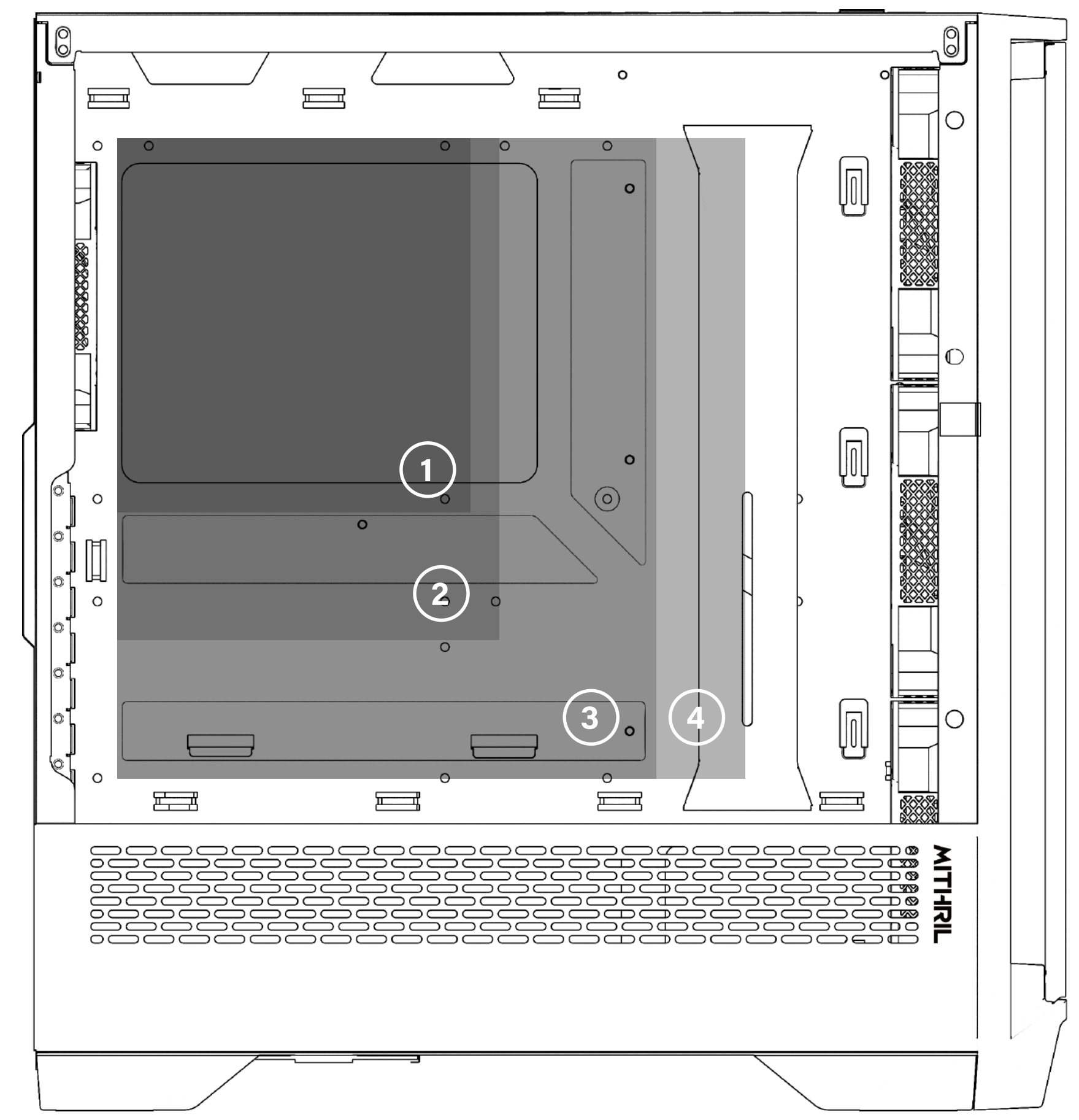

- ① Mini-ITX
- ② Micro-ATX
- ③ ATX
- ④ E-ATX

Asegúrate que la placa base se alinea con los huecos marcados en la torre e instala los alzadores de cobre (No.2) antes de atornillar la placa base a la torre con los tornillos No.3

D

Instalación de discos duros HDD/SSD.

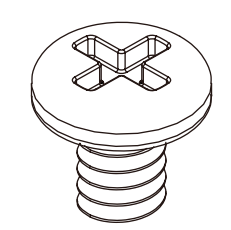
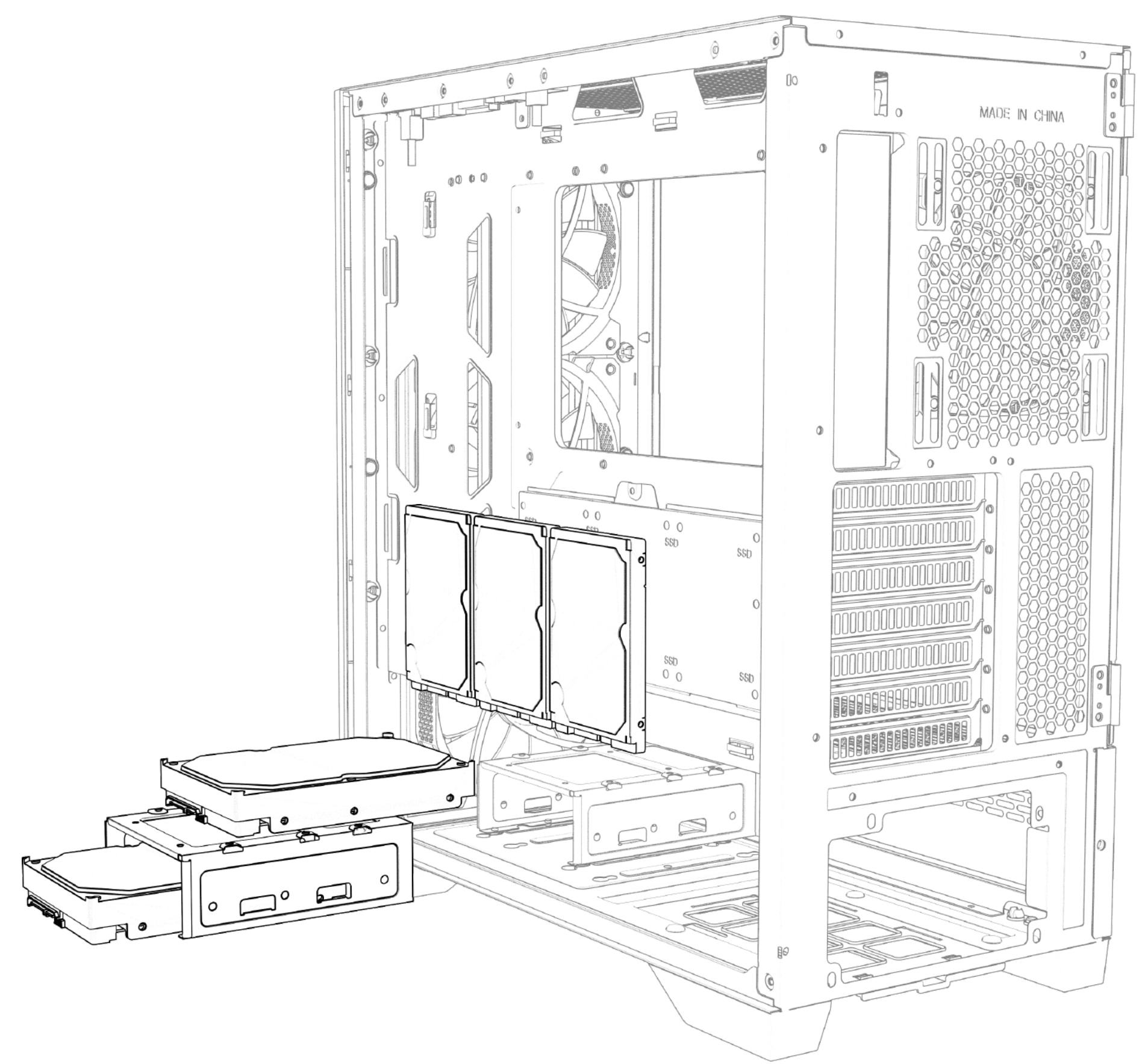

Desmonta el soporte para los discos HDD y SSD e instálalos con los tornillos No.4

E

Instalación de tarjeta gráfica y desmontar el slot de expansión PCI.

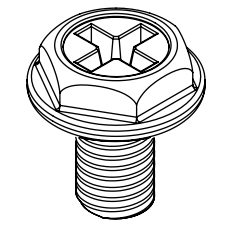
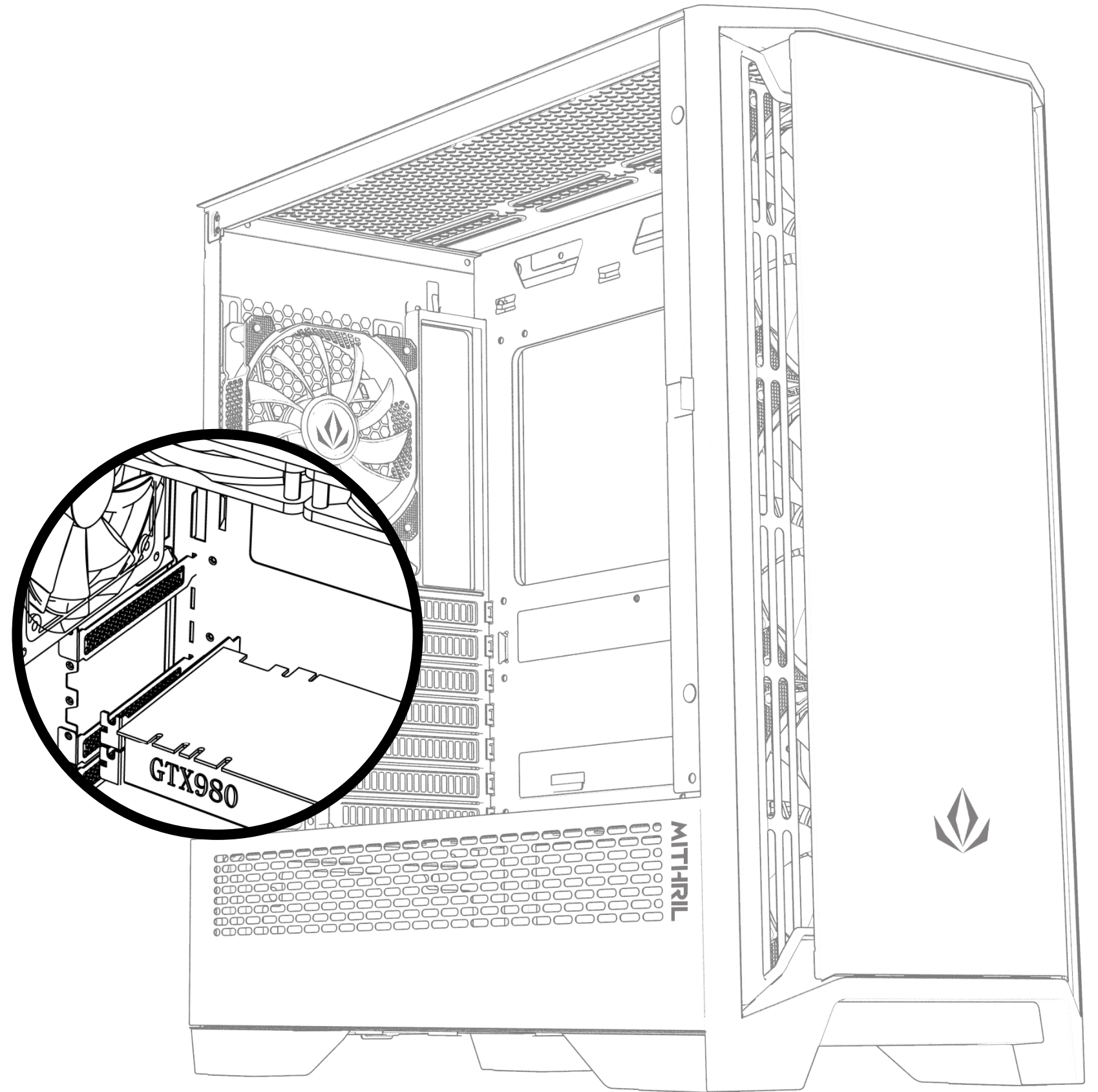

Retira el embellecedor que necesitas alineando con la ranura PCI de la placa base, luego instala la tarjeta gráfica y asegúrala a la torre con el tornillo No.1

F

Instalación de ventiladores y/o radiadores (opcional).

(A)

FRONTAL

Ventiladores → 3x 120mm
→ 3x 140mm
Radiador hasta 360mm

(B)

SUPERIOR

Ventiladores → 3x 120mm
→ 3x 140mm
Radiador hasta 360mm

(C)

TRASERO

Ventiladores → 1x 120mm
→ 1x 140mm
Radiador hasta 120mm

(D)

BASE

Ventiladores → 1x 120mm

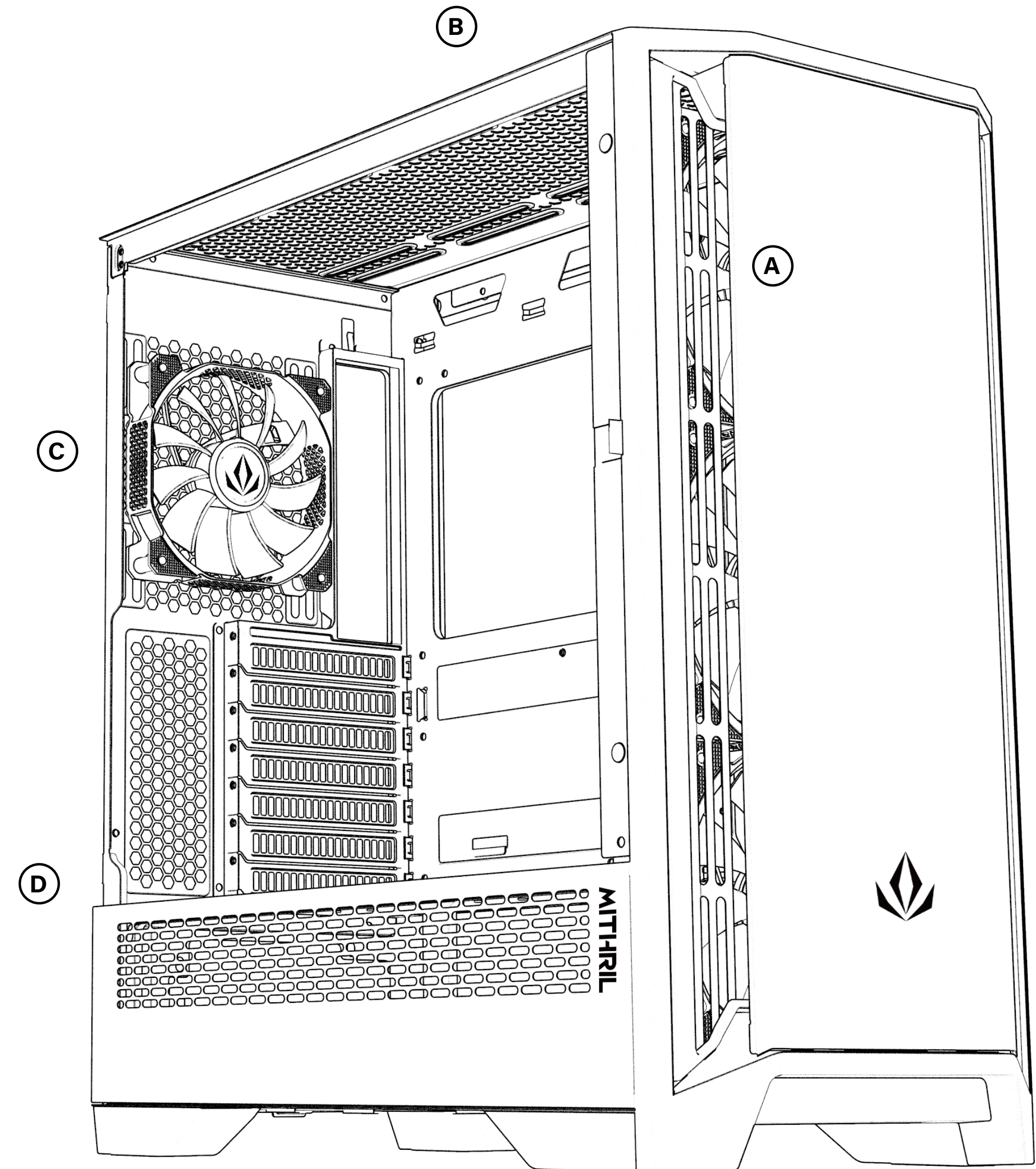

G

Configuración e instalación de la controladora RGB

- A** Conector A-RGB 3pin 5v
- B** Conector de alimentación 3pin
- C** Conectores alimentación 4pin (PWM) y sincronización A-RGB 5v 3pin para placa base
- D** Conector SATA para fuente de alimentación



La controladora incluye 4pines de salida de alimentación (PWM),si el ventilador tiene solo 3, conéctalo saltándote el último empezando desde la izquierda.

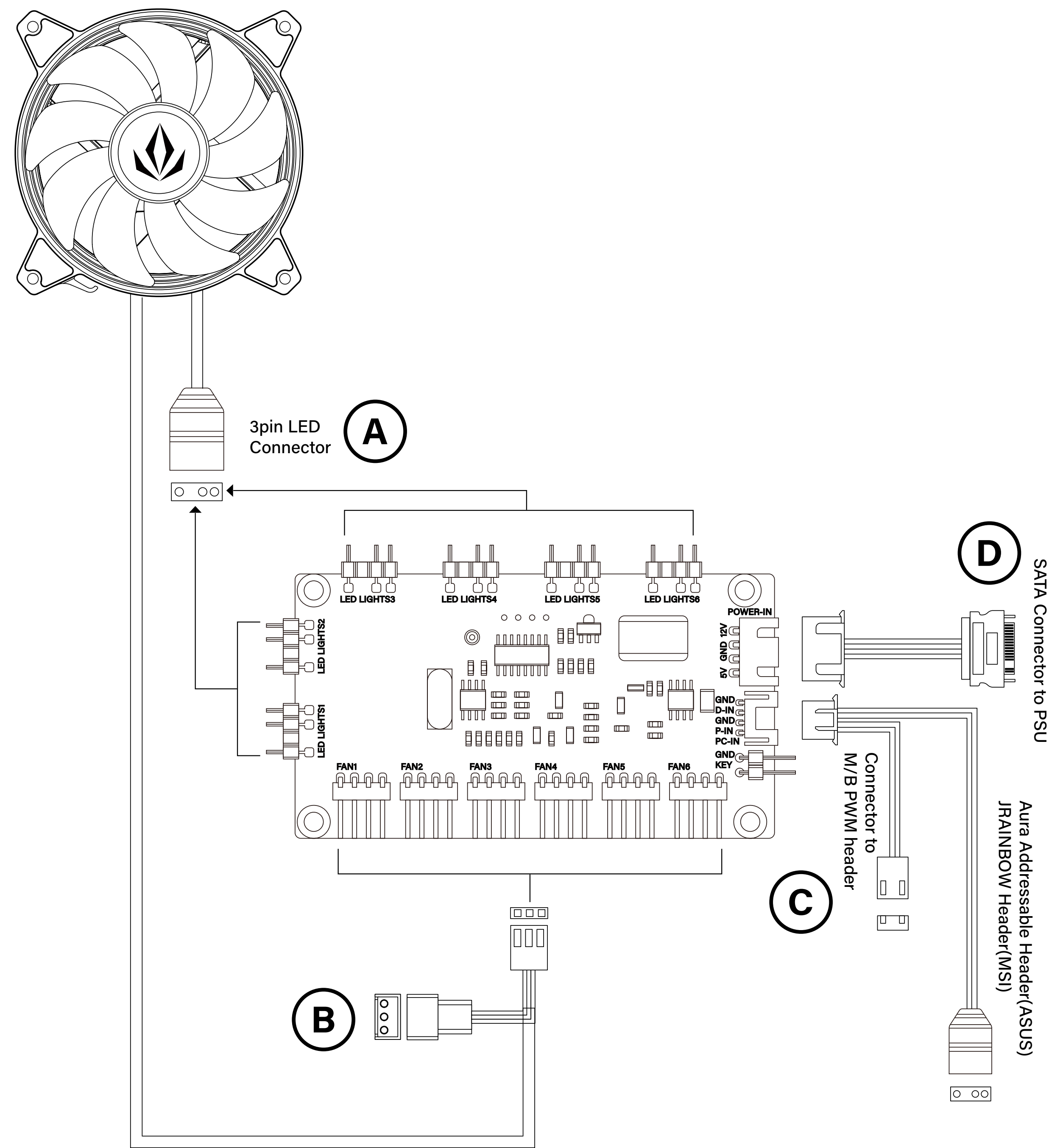



 FORGEON
MITHRIL